

# Acer Universal Ceiling Mount

- Adapted for any Acer projector
- Tool less adjustment
- 360 degree rotate
- $\pm 25$  degree tilt

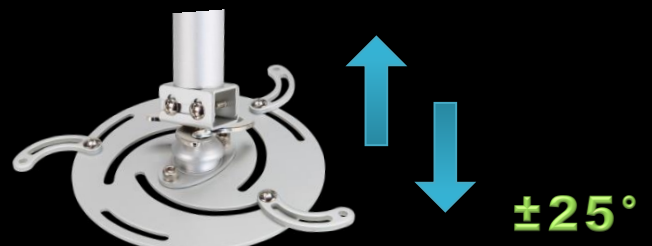

1. Drill four holes into a solid, structural ceiling member, and secure the ceiling mount base to the ceiling.

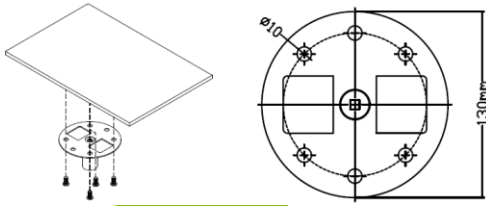

3. Type 1: For the standard size use three bracket screws to mount the projector to the ceiling mount bracket.  
Type 2 and Type 3: Alternatively, for the larger size, use the sliding extensions for more supports.

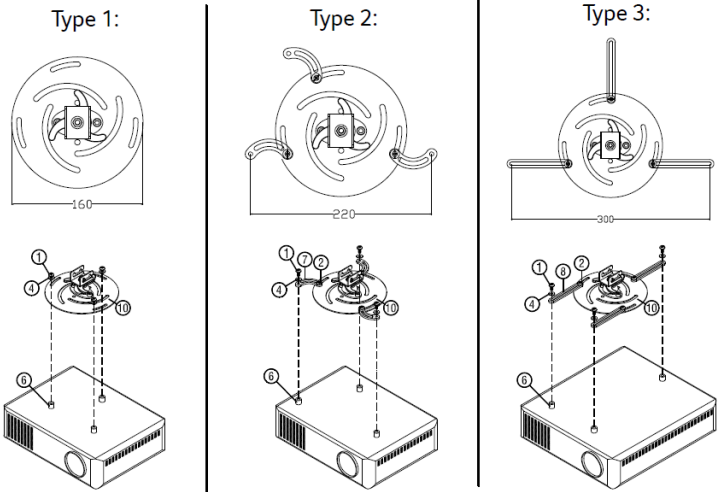

2. Choose the length combination based on actual environment. (CM-01S doesn't include Type 2 and Type 3.)

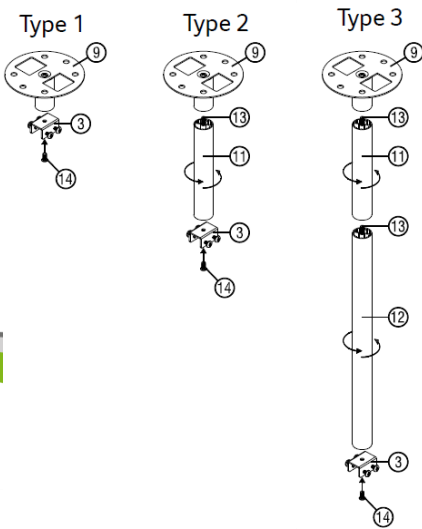

4. Connect the main body connector to the projector bracket (illustration 1), and then screw up four screws (illustration 2).

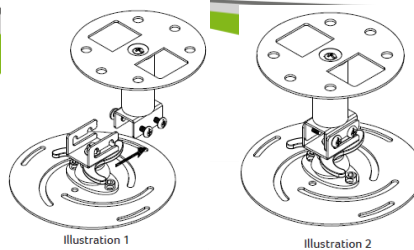

5. Adjust the angle and positioning as necessary.



## Product Specifications

Model	CM-01S	CM-02S
Material	Aluminum	
Max. Distance to Ceiling	11 cm (One Tube)	64 cm (Three Tubes)
Max. Length of Bracket with Extension Hook	300 mm	
Weight Capability	20KG (44lbs)	
Swivel Angle	360°	
Tilt Angle	+/- 25°	
Screw Type	M3/M4	
Color	Silver	

### Acer

Since its founding in 1976, Acer has achieved the goal of breaking the barriers between people and technology. Globally, Acer ranks No. 2 for notebook PCs.<sup>1</sup> A profitable and sustainable Channel Business Model is instrumental to the company's continuing growth, while its multi-brand approach integrates Acer, Gateway, Packard Bell, and eMachines brands in worldwide markets. Acer designs environmentally friendly products and has established a green supply chain through collaboration with suppliers. Acer is proud to be a Worldwide Partner of the Olympic Movement, including supporting the Vancouver 2010 Olympic Winter Games and London 2012 Olympic Games. The Acer Group employs 8,000 people worldwide. Revenues for 2010 reached US\$19.9 billion. Visit [www.acer-group.com](http://www.acer-group.com) for more information.

<sup>1</sup> Source: Gartner data Q3 2011.