

AV813

PROJECTOR CEILING MOUNT



DESCRIPTION

Its extremely flexible design allows you to fit almost any popular projector in the industry under 44 lbs (20kg). It is featured with 2 different length of extension arms that allows flexible positioning to fit almost any projector mounting point. With these extensions, arms position around lamp and filter have easy access/maintenance to maximize lamp life. With spacers provided, the mount is able to adapt to any projector base, no matter how oddly shaped, to maintain a level installation.

FEATURES

- Fast and easy installation
- Ceiling-mount capability
- Extremely flexible design allow to fit almost all popular projectors
- Quick release universal mount for Projector
- 360 degrees Rotate for Projector
- +/- 20 degrees Tilt and Roll for Projector
- Adjustable-height from 11.42" to 32" (290mm-810mm)
- Cable-routing channel for a clean look
- Cable management

TECHNICAL SPECIFICATION

GROSS WEIGHT:	4.3kg (9.2 lbs)
GROSS DIMENSION:	430 X 150 X 100 mm 17" x 6" x 4" inch
EXTENDABLE LENGTH WITH OPTIONAL ROD:	700 mm Ø 35mm & Ø 40mm
LOAD CAPACITY:	20kg (44 lbs)
COLOR OPTION:	Black

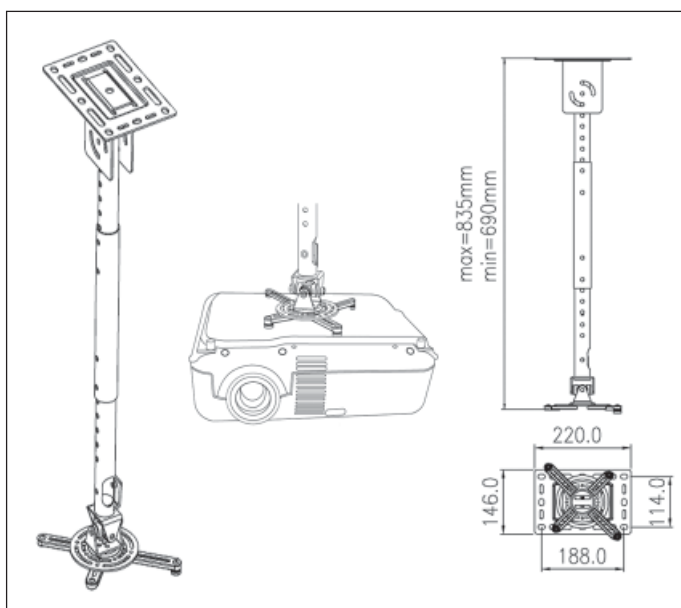

* Specifications are subject to change without notice.